



648 Superior Avenue • Munster, IN 46321  
 (219)922-4440 FAX (219)922-4442

ULTRA STAR  
 SUPER STAR  
 ATA STAR-3/8"  
 ATA STAR-1/4"  
 ATA JUNIOR-1/4"  
 CARRY STAR  
 STAR LIGHT (recessed)  
 STAR LIGHT (surface)  
 EXPO STAR

# STARCASE TYPES

## ULTRA Star Recommendations

Recommended Means of Transit	Recommended Load Limits	Recommended Size Constraints	Recommended Applications	For Additional data such as:
Common Carrier transport by: - All Air Carriers - Rail - Sea - Truck, and other land transport means	- Contents of ULTRA Star Cases should not exceed 500 pounds	- Size of ULTRA Star Cases should not exceed a combined total of Width + Depth + Height of 184 total inches	Components of high weight concentrations such as: - Computer & office Printers - Field instrumentation - Delicate equipment & electronics - VCR's & cameras	- Color Choices - Option Choices - Caster Selections  Please Consult STAR CASE Contact Us Today!

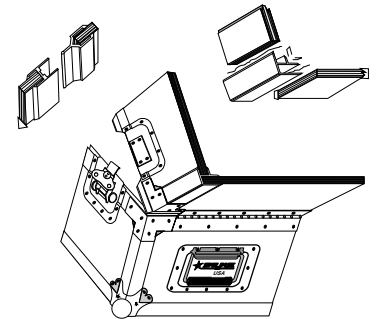

## SUPER Star Recommendations

Recommended Means of Transit	Recommended Load Limits	Recommended Size Constraints	Recommended Applications	For Additional data such as:
Common Carrier transport by: - All Air Carriers - Rail - Sea - Truck, and other land transport means	- Contents of SUPER STAR CASES should not exceed 200 pounds	- Size of SUPER STAR CASES should not exceed a combined total of Width + Depth + Height of 160 total inches	Components of high weight concentrations such as: - Computer & office Printers - Field instrumentation - Delicate equipment & electronics - VCR's & cameras	- Color Choices - Option Choices - Caster Selections  Please Consult STAR CASE Contact Us Today!

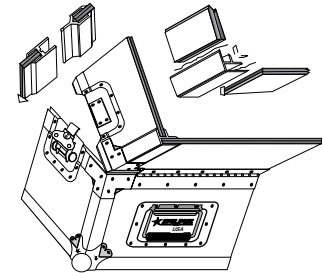

## ATA Star-3/8" Recommendations

Recommended Means of Transit	Recommended Load Limits	Recommended Size Constraints	Recommended Applications	For Additional data such as:
Common Carrier transport by: - All Air Carriers - Rail - Sea - Truck, and other land transport means	- Contents of ATA Star-3/8" Cases should not exceed 200 pounds	- Size of ATA Star-3/8" Cases should not exceed a combined total of Width + Depth + Height of 160 total inches	Components of mid-weight concentrations such as: - Computer & office Printers - Field instrumentation - Delicate equipment & electronics - VCR's & cameras	- Color Choices - Option Choices - Caster Selections  Please Consult STAR CASE Contact Us Today!

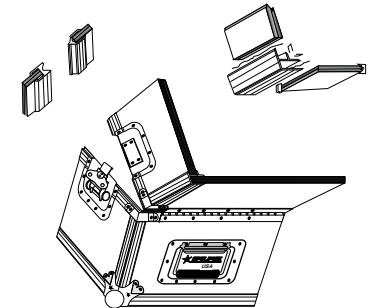

## ATA Star-1/4" Recommendations

Recommended Means of Transit	Recommended Load Limits	Recommended Size Constraints	Recommended Applications	For Additional data such as:
Common Carrier transport by: - All Air Carriers - Rail - Sea - Truck, and other land transport means	- Contents of ATA Star-1/4" Cases should not exceed 150 pounds	- Size of ATA Star-1/4" Cases should not exceed a combined total of Width + Depth + Height of 130 total inches	Components of mid-weight concentrations such as: - Computer & office Printers - Field instrumentation - Delicate equipment & electronics - VCR's & cameras	- Color Choices - Option Choices - Caster Selections  Please Consult STAR CASE Contact Us Today!

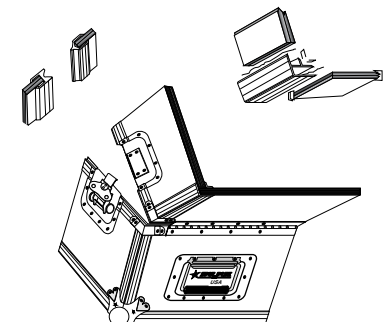

## ATA STAR JUNIOR-1/4" Recommendations

Recommended Means of Transit	Recommended Load Limits	Recommended Size Constraints	Recommended Applications	For Additional data such as:
<ul style="list-style-type: none"> <li>Common Carrier transport by:</li> <li>- All Air Carriers</li> <li>- Rail</li> <li>- Sea</li> <li>- Truck, and other land transport means</li> </ul>	<ul style="list-style-type: none"> <li>- Contents of ATA Junior-1/4" Cases should not exceed 60 pounds (with case cart option-30 pounds)</li> </ul>	<ul style="list-style-type: none"> <li>- Size of ATA Junior-1/4" Cases should not exceed a combined total of Width + Depth + Height of 100 total inches</li> </ul>	<ul style="list-style-type: none"> <li>Components of mid-weight concentrations such as:</li> <li>- Computer &amp; LCD projectors</li> <li>- LCD Flat Panel Displays</li> <li>- Delicate equipment &amp; electronics</li> </ul>	<ul style="list-style-type: none"> <li>- <i>Color Choices</i></li> <li>- <i>Option Choices</i></li> <li>- <i>Caster Selections</i></li> </ul> <p>Please Consult STAR CASE Contact Us Today!</p>

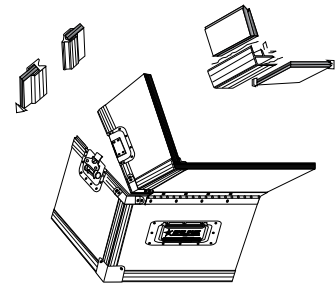

## CARRY STAR Recommendations

Recommended Means of Transit	Recommended Load Limits	Recommended Size Constraints	Recommended Applications	For Additional data such as:
<ul style="list-style-type: none"> <li>- Surface travel</li> <li>- Automobile</li> <li>- Local van transit</li> <li>- Not recommended for common carrier transit</li> </ul>	<ul style="list-style-type: none"> <li>- Contents of CARRY STAR Cases should not exceed 30 pounds</li> </ul>	<ul style="list-style-type: none"> <li>- Size of CARRY STAR Cases should not exceed a combined total of Width + Depth + Height of 90 total inches</li> </ul>	<ul style="list-style-type: none"> <li>- Laptop computers</li> <li>- Small instruments</li> <li>- Portable VCR's &amp; cameras</li> <li>- Sales Samples</li> <li>- Briefcase applications</li> </ul>	<ul style="list-style-type: none"> <li>- <i>Product Specifications</i></li> <li>- <i>Option Choices</i></li> <li>- <i>Caster Selections</i></li> </ul> <p>Please Consult STAR CASE Contact Us Today!</p>

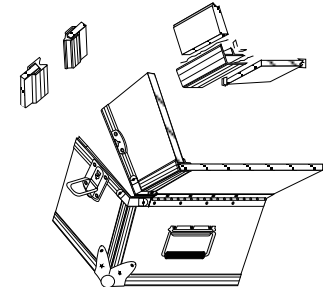

## CARRY LIGHT (recessed hardware) Recommendations

Recommended Means of Transit	Recommended Load Limits	Recommended Size Constraints	Recommended Applications	For Additional data such as:
<ul style="list-style-type: none"> <li>- Surface travel</li> <li>- Automobile</li> <li>- Local van transit</li> <li>- Not recommended for common carrier transit</li> </ul>	<ul style="list-style-type: none"> <li>- Contents of CARRY LIGHT Cases should not exceed 20 pounds</li> </ul>	<ul style="list-style-type: none"> <li>- Size of CARRY LIGHT Cases should not exceed a combined total of Width + Depth + Height of 70 total inches</li> </ul>	<ul style="list-style-type: none"> <li>- Laptop computers</li> <li>- Small instruments</li> <li>- Portable VCR's &amp; cameras</li> <li>- Sales Samples</li> <li>- Briefcase applications</li> </ul>	<ul style="list-style-type: none"> <li>- <i>Product Specifications</i></li> <li>- <i>Option Choices</i></li> <li>- <i>Caster Selections</i></li> </ul> <p>Please Consult STAR CASE Contact Us Today!</p>

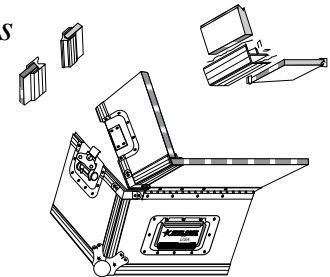

## CARRY LIGHT (surface hardware) Recommendations

Recommended Means of Transit	Recommended Load Limits	Recommended Size Constraints	Recommended Applications	For Additional data such as:
<ul style="list-style-type: none"> <li>- Surface travel</li> <li>- Automobile</li> <li>- Local van transit</li> <li>- Not recommended for common carrier transit</li> </ul>	<ul style="list-style-type: none"> <li>- Contents of STAR LIGHT Cases should not exceed 30 pounds</li> </ul>	<ul style="list-style-type: none"> <li>- Size of STAR LIGHT Cases should not exceed a combined total of Width + Depth + Height of 90 total inches</li> </ul>	<ul style="list-style-type: none"> <li>- Laptop computers</li> <li>- Small instruments</li> <li>- Portable VCR's &amp; cameras</li> <li>- Sales Samples</li> <li>- Briefcase applications</li> </ul>	<ul style="list-style-type: none"> <li>- <i>Product Specifications</i></li> <li>- <i>Option Choices</i></li> <li>- <i>Caster Selections</i></li> </ul> <p>Please Consult STAR CASE Contact Us Today!</p>

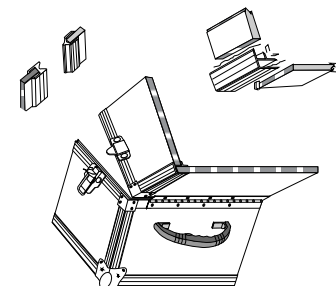

## EXPO STAR (1/2", 3/8", 1/4" & 1/8" Recommendations

Recommended Means of Transit	Recommended Load Limits	Recommended Size Constraints	Recommended Applications	For Additional data such as:
<ul style="list-style-type: none"> <li>- Surface travel</li> <li>- Automobile</li> <li>- Local van transit</li> <li>- Most common carrier means of transit</li> </ul>	<ul style="list-style-type: none"> <li>- Contents of EXPO STAR Cases should be considered individually. Please contact us for recommendations.</li> </ul>	<ul style="list-style-type: none"> <li>- Size of EXPO STAR Cases should be considered individually. Please contact us for recommendations.</li> </ul>	<ul style="list-style-type: none"> <li>- Graphic Panels</li> <li>- Exhibit Panels</li> <li>- Light weight, awkward shaped items</li> <li>- Artwork</li> </ul>	<ul style="list-style-type: none"> <li>- <i>Product Specifications</i></li> <li>- <i>Option Choices</i></li> <li>- <i>Caster Selections</i></li> </ul> <p>Please Consult STAR CASE Contact Us Today!</p>

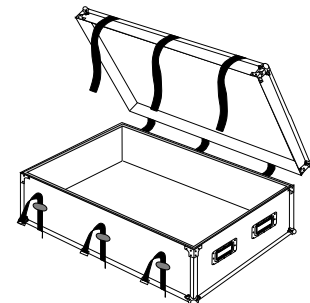

All Star Case "Types" (with the exception of Star Light) are constructed of premium grade plywood walls with a tough fiberglass outer laminate.

All case walls are bonded with proprietary double-walled aluminum extrusions.

Case closure (except our telescoping lid design Expo Star line) is by means of proprietary, positive-fitting, aluminum tongue & groove valance extrusions.

All Star Case "Types" incorporate extrusions and hardware that coordinate properly with the case plywood wall thickness.

All case types except Star Light are available in 10 color choices: red, white, blue, green, yellow, orange, light gray, dark gray, black or Bordeaux.

Star Light is manufactured of specially extruded 400# test HDPE (high density polyethylene) and is available in black only.

STAR CASE MANUFACTURING CO., INC.

648 Superior Avenue

Munster, IN 46321

(219)922-4440 FAX: (219)922-4442

TOLL-FREE:

(800)822-STAR

(800)782-CASE

email: [starcase@starcase.com](mailto:starcase@starcase.com)

URL: <http://www.starcase.com>