

STAR LIGHT

(recessed hardware)

STANDARD ON STAR LIGHT

Tongue & groove valance of mill-finish aluminum makes upper and lower section alignment precise and closure positive

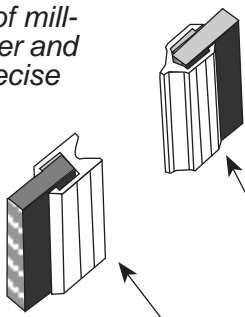

STANDARD ON ATAR LIGHT

Flat black-finish on Star Light gives excellent protection and long lasting durability

STANDARD ON STAR LIGHT

Inner & outer wall double-walled aluminum angle extrusion provides added skeletal strength to case framework

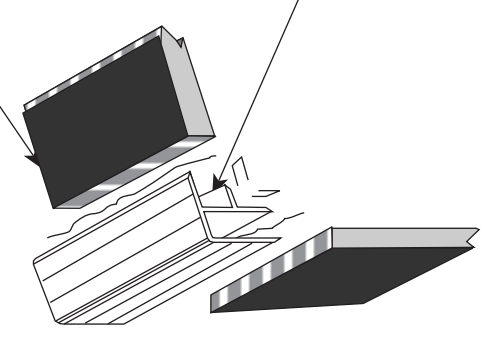

STANDARD ON STAR LIGHT

Steel spring-loaded twist catches mounted in recessed resin plastic dish assemblies are standard issue on Star Light

STANDARD ON STAR LIGHT

Steel construction corner clamps provide excellent support to the critical lid opening on all STAR LIGHT Cases

STANDARD ON STAR LIGHT

Honeycomb fluted polypropylene outer wall material is both ultra-lightweight and impervious to almost all chemical compounds

STANDARD ON STAR LIGHT

Only the finest grades of 1/4" cross fluted, 400# test, honeycomb structure polypropylene is used on STAR LIGHT Cases

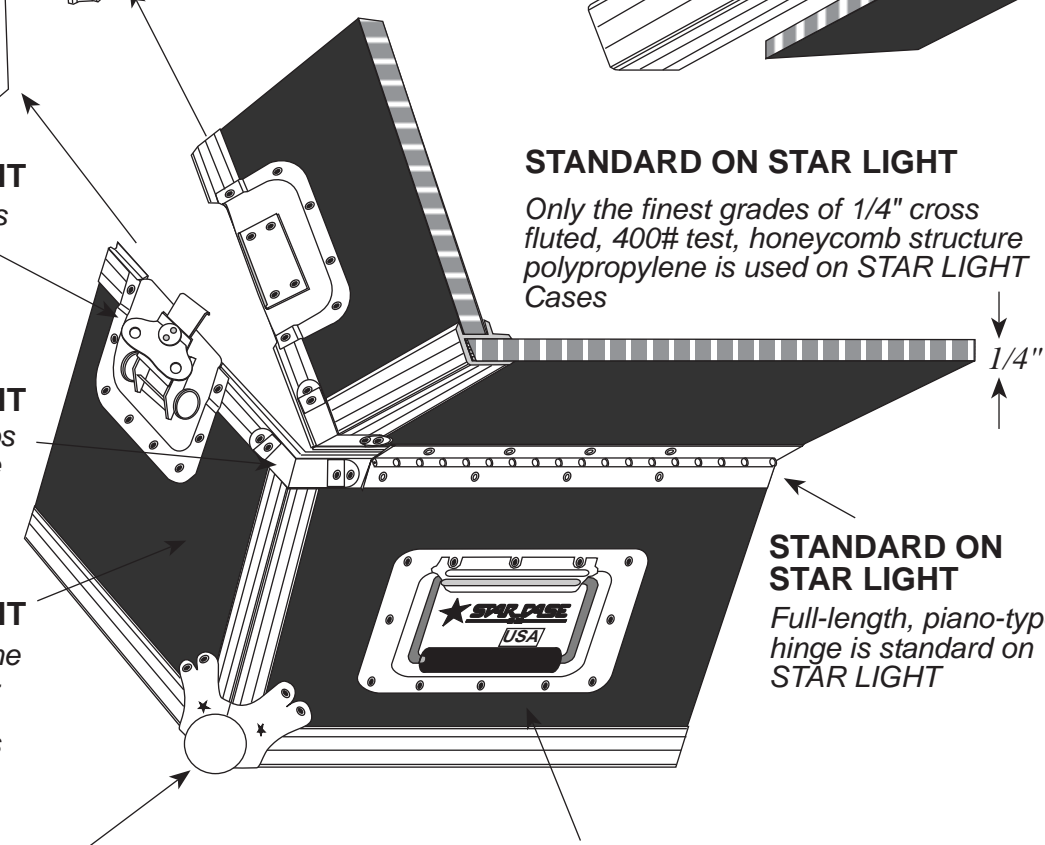

STANDARD ON STAR LIGHT

Full-length, piano-type hinge is standard on STAR LIGHT

STANDARD ON STAR LIGHT

Heavy-gauge steel knuckled ball corners protect all outer corners while elevating case surface a minimum of 1/4" from ground level

STANDARD ON STAR LIGHT

Recessed and spring-loaded handles with large rubber grips are conveniently placed for greatest ease of transport

STAR LIGHT - *(recessed hardware)* Recommendations

Recommended Means of Transit	Recommended Applications	For Additional data such as: - <i>Color Choices</i> - <i>Option Choices</i> - <i>Caster Selections</i> Please Consult STAR CASE Contact Us Today!
Common Carrier transport by: - All Air Carriers - Rail - Sea - Truck, and other land transport means	Components of high weight concentrations such as: - LCD/Plasma displays. - Trades show supplies - Delicate equipment & electronics - Medical Instruments	